

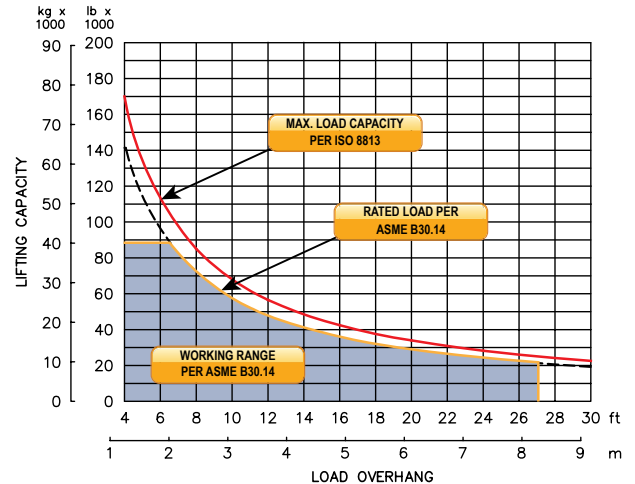

LOAD RATING



FEATURES

Multi-functional joystick controller allows simultaneous, precise control of the load and boom functions with one hand. Built in electronic switches are used for counterweight and two-speed functions. The controls are easy to operate and require minimal operator training.

High capacity pipelayer winch package with high efficiency, two-speed piston motors.

Superb Operator Visibility due to new compact sideboom attachment design.

Hydraulically operated, four-bar linkage counterweight system adds maximum stability and lifting capability. Low, compact design provides balanced weight distribution for optimum operating control and excellent visibility.

Emergency free-fall function on load winch. Allows the operator to drop the load quickly in an emergency situation.

Electrohydraulic boom stop automatically prevents system over travel and damage to boom.

System ties into tractor's existing hydraulic system for convenience of OEM replacement parts and maintenance.

Tubular A-frame boom with quick release hinge pins for easy boom removal and maintenance.

Load Indicator System displays rated capacity, weight of the load on hook, load overhang and slope.

Optional 28 ft boom length and Anti-2-Block System available.

SIDEBOOM ATTACHMENTS

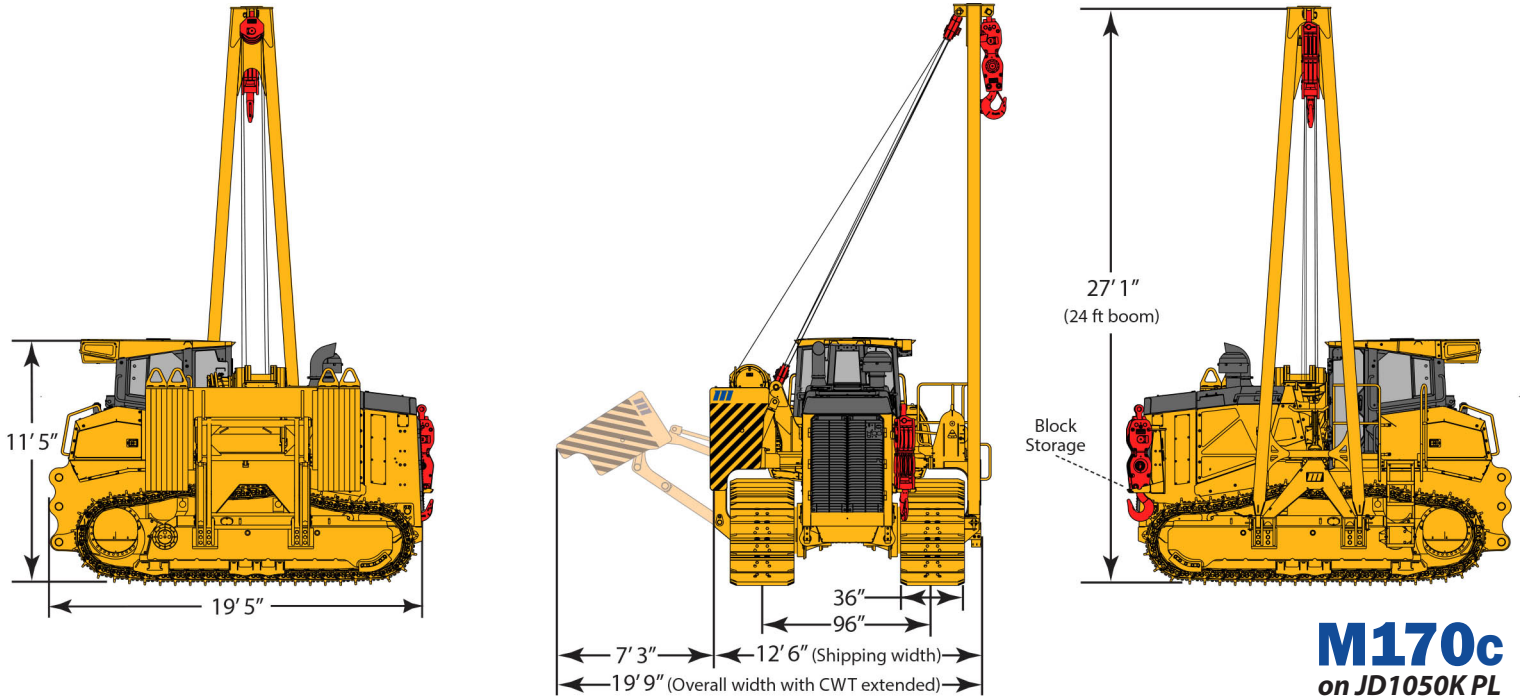

M170c
on JD1050K PL

Load Capacity	
Maximum Load at 4 ft Overhang	170,000 lb (77,110 kg)
Rated Load at 4 ft Overhang	144,500 lb (65,544 kg)
Maximum Working Load at 4 ft Overhang	88,200 lb (40,006 kg)
Boom and Blocks	
Standard Boom	24 ft (7.3 m)
Boom Line Parts	5
Load Line Parts	6
Typical Hook Speed	60/30 ft/min (18/9 m/min)
Winches	
Boom Winch	Planetary, Two-Speed, Dual Brake System
Load Winch	Planetary, Two-Speed, Dual Brake System, Free-Fall
Wire Rope Installed - Boom Winch	210 ft (64 m)
Maximum Cable Capacity - Boom Winch	319 ft (97 m)
Wire Rope Installed - Load Winch	245 ft (75 m)
Maximum Cable Capacity - Load Winch	391 ft (119 m)
Wire Rope - Boom & Load Line	3/4 in (19 mm), 6x36 EIPS, IWRC [58,800 lbs (26,671 kg) Minimum Breaking Strength]
Hydraulic System	
Directional Control Valve	3-Section, Load Sense, Pressure Compensated w/ Electrohydraulic Controls
Operating Pressure	4,500 psi (310 bar)
Pump Output	100 gpm (379 lpm)
Weights	
Removable Counterweight Segments	17,560 lb (4 @ 4,390 lb) (7,965 kg, 4 @ 1,1991 kg)
Total Extendible Counterweight (Segments & Frame)	23,370 lb (10,600 kg)
Total Sideboom Attachment Weight	38,200 lb (17,328 kg)
Approximate Operating Weight	123,200 lb (55,884 kg)
Approx. Shipping Weight - Less Boom & Counterweights	102,950 lb (46,698 kg)